REPUBLIC OF MOLDOVA

MOLDOVA RURAL CONNECTIVITY PROJECT - P180153

NATIONAL ROAD ADMINISTRATION

Minutes of Pre-Bid Meeting

**Rehabilitation of M1 Road: Romanian border – Leuşeni
- Chişinău – Dubăsari - Ukrainian Border, km 0+000 –
km 1+000 (BCP Leuşeni)**

Issued on April 3rd, 2026

Location: National Road Administration (NRA)
Bucuriei 12A str., MD – 2004, 4th floor, office 400
Chișinău, Republic of Moldova

Time: 10:30 am (local time)

Date: April 3rd, 2026

Attendance:

Client's representatives:

- Mrs. Natalia CAPAȚÎNA, Chief of Procurement Section, Foreign Investments Department, National Road Administration;
- Mr. Nichita PURICI, Chief of Engineering Management Section, Foreign Investments Department, National Road Administration;
- Ms. Liuba ȚURCAN, Consultant of Engineering Management Section, Foreign Investments Department, National Road Administration;

The List of Participants, completed and signed by all attendees, is attached hereto (see Annex A).

Opening:

Mrs. Natalia CAPAȚÎNA has welcomed all the participants and has introduced the reason of the meeting. Further she has pointed out to the participants that the event was held in accordance with para 7.4, Section I - Instructions to Bidders, Bidding Documents, aimed at clarifying issues and answering questions on any matters that may be raised at this stage.

Attendees have been informed that the meeting's presentation does not replace or modify any provisions of the bidding document mentioned above. In case of contradiction between the presentation and the bidding document, the terms and conditions of the bidding document take precedence.

Mr. Nichita PURICI has continued the presentation on the scope of works and has made a brief overview on the geometrical parameters of the roads, major structural works and main estimated quantities for the respective works contract.

Discussions:

Participants raised their questions and some of them were further discussed and answered in general lines. Mrs. Natalia CAPAȚÎNA has specified that all the questions will be formally answered through the Clarification Document approved by the Bank, that will be made public to all interested bidders.

Closing:

At the end, Mrs. Natalia CAPAȚÎNA thanked the representatives of firms for their attendance, and wished them good luck in the bidding process.

Note:

The information presented during the Pre-Bid meeting is not exhaustive, it provided only a summary of the most important issues and clauses from Bidding Documents, therefore in preparing their Bids, the bidders should follow the complete set of Bidding Documents, including answers to the Requests for Clarification and Amendments, if appropriate.

Annexes:

- Annex A – List of Participants at the Pre-Bid Meeting.
- Annex B – Meeting's presentation.

Rehabilitation of M1 Road: Romanian border – Leușeni – Chișinău – Dubăsari - Ukrainian Border,
km 0+000 – km 1+000 (BCP Leușeni)

Annex A
List of Participants at the Pre-Bid Meeting

Annex A

List of Participants at the Pre-Bid Meeting

RFB No. MRCP/W7/01

**Rehabilitation of M1 Road: Romanian border-Leușeni-Chișinău-Dubăsari-Ucrainian
Border, km 0+000 – km 1+000 (BCP Leușeni)**

Pre-Bid Meeting held on April 3rd, 2026 at S.A. „Administratia Nationala a Drumurilor” (National Road Administration), 4th floor, Room 400, Bucuriei 12A str, Chisinau, MD – 2004, Republic of Moldova

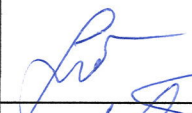
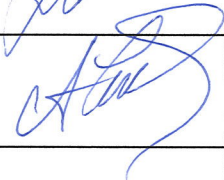
No.	Name of Bidder	Country of Bidder	Name of Bidder's Representative	Signature of Representatives
1	STRABAG SRL	RO	DANDARA OCTAVIAN	
2	STRABAG SRL	RO	ZIHA FLORIN	
3	STRABAG SRL	RO	COLAN ALIGIA	
4				
5				
6				
7				
8				
9				
10				

NRA'S REPRESENTATIVE:

Name: Wabezi Cristina

Signature: 

Rehabilitation of M1 Road: Romanian border – Leușeni – Chișinău – Dubăsari - Ukrainian Border,
km 0+000 – km 1+000 (BCP Leușeni)

Annex B
Pre-Bid Meeting's Presentation

Republic of Moldova
**The Ministry of Infrastructure and Regional
Development**



J.S.C. "National Road Administration"
Moldova Rural Connectivity Project

Rehabilitation of M1 Road: Romanian border-Leuşeni-Chişinău-
Dubăsari-Ucrainian Border, km 0+000 – km 1+000 (BCP Leuşeni)



Pre-Bid Meeting

MRCP/W7/01

April 3rd, 2026

- This presentation does not replace or modify any provisions of the bidding document mentioned above.
- In case of contradiction between this presentation and the bidding document, the terms and conditions of the bidding document take precedence.

**D
I
S
C
L
A
I
M
E
R**

SOURCE OF FUNDING

Financed by:

- 1) **The World Bank** and
- 2) **European Climate, Infrastructure and Environment Executive Agency (CINEA)**

Borrower: **The Government of the Republic of Moldova**

Client: **JSC “National Road Administration” (S.A. “Administrația Națională a Drumurilor”**

The Project is: **Moldova Rural Connectivity Project**

SELECTION PROCEDURE

Bidding will be conducted through national competitive procurement using a Request for Bids (RFB), Small Works, as specified in the World Bank's "Procurement Regulations for IPF Borrowers - Procurement in Investment Projects Financing; Goods, Works, Non-Consulting and Consulting Services", revision September 2023 ("Procurement Regulations"), and is open to all Bidders as defined in the Procurement Regulations.

Period of Validity of Bids

**120 calendar days
from the closing
date of the bid.**

SUBMISSION OF BIDS

Original Bid (one sealed envelope)

1 (one) electronic copy
(on USB-stick)

1 (one) printed copy

The envelope shall contain Letter of Bid, Bill of Quantities, Bid-Securing Declaration and other documentation (as described in ITB 11.1) shall be provided.

Joint Venture

In the case of a joint venture, all members shall be jointly and severally liable for the execution of the entire Contract in accordance with the Contract terms.

The JV shall nominate a Representative who shall have the authority to conduct all business for and on behalf of any and all the members of the JV during the Bidding process and, in the event the JV is awarded the Contract, during contract execution.

Bids submitted by a JV shall include a copy of the Joint Venture Agreement entered into by all members. Alternatively, a letter of intent to execute a Joint Venture Agreement in the event of a successful bid shall be signed by all members and submitted with the Bid, together with a copy of the proposed Agreement.

Maximum number of members in the JV shall be: 2 (two).

Subcontracting

Contractor's proposed subcontracting: Maximum percentage of subcontracting permitted is: **30%** of *the total contract amount*.

Bidders proposing to subcontract more than 10% of total volume of work shall specify, in the in Section IV-Bidding Forms, the activity (ies) or parts of the Works to be subcontracted along with complete details of the subcontractors and their qualification and experience.

QUALIFICATION REQUIREMENTS

- The qualification of the bidder submitting the lowest evaluated substantially responsive bid is assessed in accordance with the criteria specified in Section III of the Bidding Documents.

Qualification Criteria

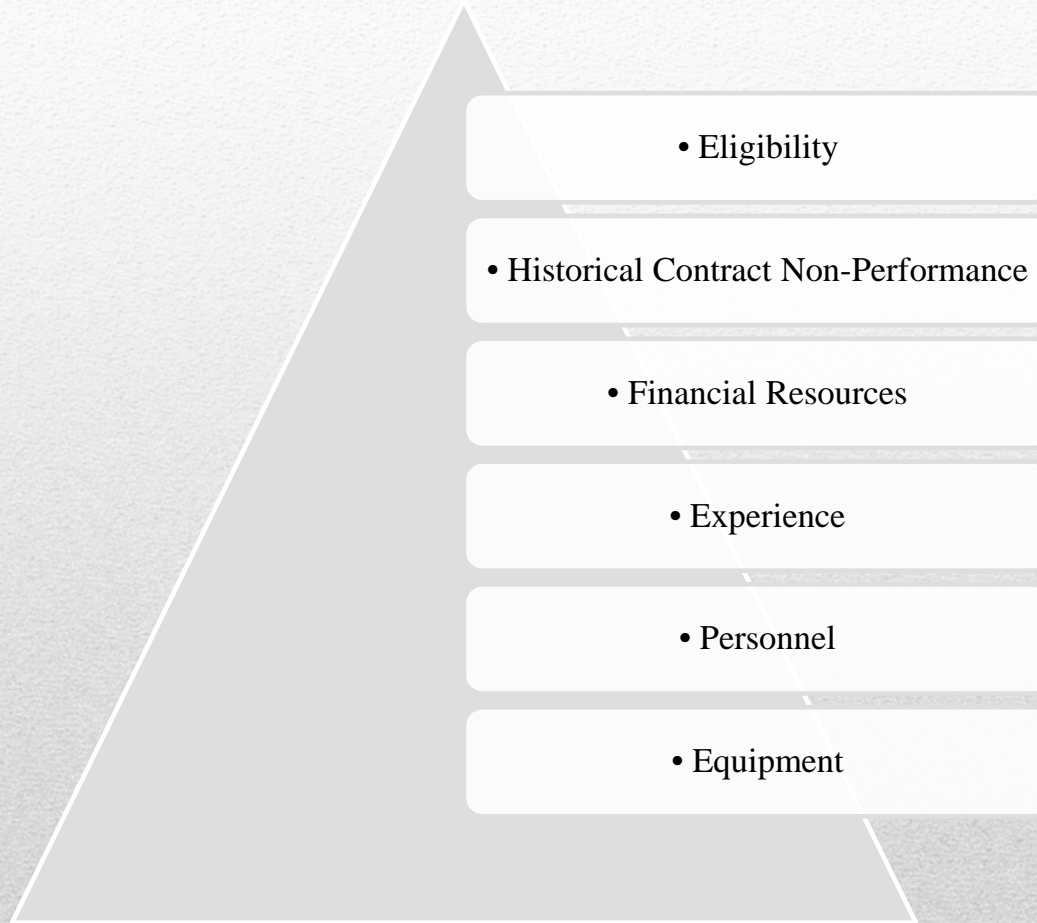

Evaluation

The Employer shall use the criteria and methodologies listed above. By applying the set criteria and methodologies, the Employer shall determine the Most Advantageous Bid. This is the Bid of the Bidder that meets the Qualification Criteria and whose Bid has been determined to be:



- (a) substantially responsive to the bidding document; and
- (b) the lowest evaluated cost.

The currency that shall be used for Bid evaluation and comparison purposes to convert at the selling exchange rate all Bid prices expressed in various currencies into a single currency is: ***EURO***.

The source of exchange rate shall be: ***National Bank of Moldova***.

The date for the exchange rate shall be: the date of bids opening.

OTHER

A Bid-Securing Declaration shall be required (ITB 19.1).

(To complete the Form of Bid-Securing Declaration in Section IV Bidding Forms).

Bid Security is NOT required!!!



The prices quoted by the Bidder **shall not** be subject to adjustment.

Electronic Bidding is not permitted.

Environmental and Social (ES) Performance Security is NOT required.

Duration of the Contract:

- The contract is expected to start in July 2026
 - **Time for completion:**
 - **365 days from the Commencement Date**
 - **+ 1 year DNP**
-

SUPERVISION OF CIVIL WORKS

The Project manager will be notified to the successful bidder prior to the Commencement Date.

If the Project Manager is not available at the date of Contract Agreement or becomes unavailable during the term of the Contract, the Employer exercise Engineer's Duties and Authorities on an interim basis, in order not to delay the Contract performance.

Tax and Custom Facilities

In accordance with the applicable law, no duties, taxes, or other levies shall be payable by the Contractor under the Contract. No such duties, taxes, or other levies shall be included in the rates and prices or in the total Bid Price submitted by the Bidders and shall not be paid and/or reimbursed by the Employer.

Law No. 176 dated July 11, 2024, on the ratification of the Loan Agreement between the Republic of Moldova and the International Bank for Reconstruction and Development, and Law No. 177 dated July 11, 2024, on the ratification of the Financing Agreement between the Republic of Moldova and the International Development Association for the implementation of the Moldova Rural Connectivity Project, provide the Contractor with VAT exemption with the right to deduct and, respectively, exemption from excise duty, customs duties, fees for customs procedures, and VAT exemption without the right to deduct.

Environmental & Social Requirements

- The Contractors should follow a set of environmental guidelines for contractors prescribed by the ESMP;
- Contractors should submit, as part of their bid, a site-specific Contractor's Environmental and Social Management Plan (C-ESMP based on ESMP attached to BD, with the detailed description of implementing arrangements) including implementation staff.

Health & Safety Requirements

- A Health and Safety Plan must be prepared and approved prior to any works commencing on site. The H&S Plan must demonstrate the Contractor's understanding of how to manage safety and a commitment to providing a workplace that enables all work activities to be carried out safely. The H&S Plan must detail reasonably practicable measures to eliminate or minimize risks to the health, safety and welfare of workers, contractors, visitors, and anyone else who may be affected by the operations taking into consideration that is a border zone.

The H&S Plan must be prepared in accordance with the World Bank's EH&S Guidelines and the relevant Moldova health and safety legislation.

The H&S Plan must be overseen by dedicated OHS personnel with appropriate qualifications.

Contractors should pay attention on requirements of Labor Management Procedures (LMP).

M1 Road: Romanian border-Leușeni-Chișinău-Dubăsari-Ucrainian Border, km 0+000 – km 1+000 (BCP Leușeni)



Scope of Works

The rehabilitation works of the M1 road, Romanian Border – Leușeni – Chișinău – Dubăsari – Ukrainian Border, km 0+000 – km 1+000.

The main works consist from followings quantities:

- o Over 14.000 cub.m of Earthworks;
- o Over 1.150 cub.m of asphalt concrete milling to any depth;
- o Over 13.200 square metre of foundation layer mixture of cement stabilized aggregates;
- o Over 2.800 cub.m. of cement concrete for road pavement;
- o Over 1200 linear meters of transversal drain with pipe drain;
- o Over 380 linear meters of guardrail installation;
- o Over 160 linear meters of reinforced concrete barrier (type New Jersey);
- o Over 550 linear meters of galvanized metal fence;
- o Utilities rearrangement as road illumination, communication cables, and underground sewerage.

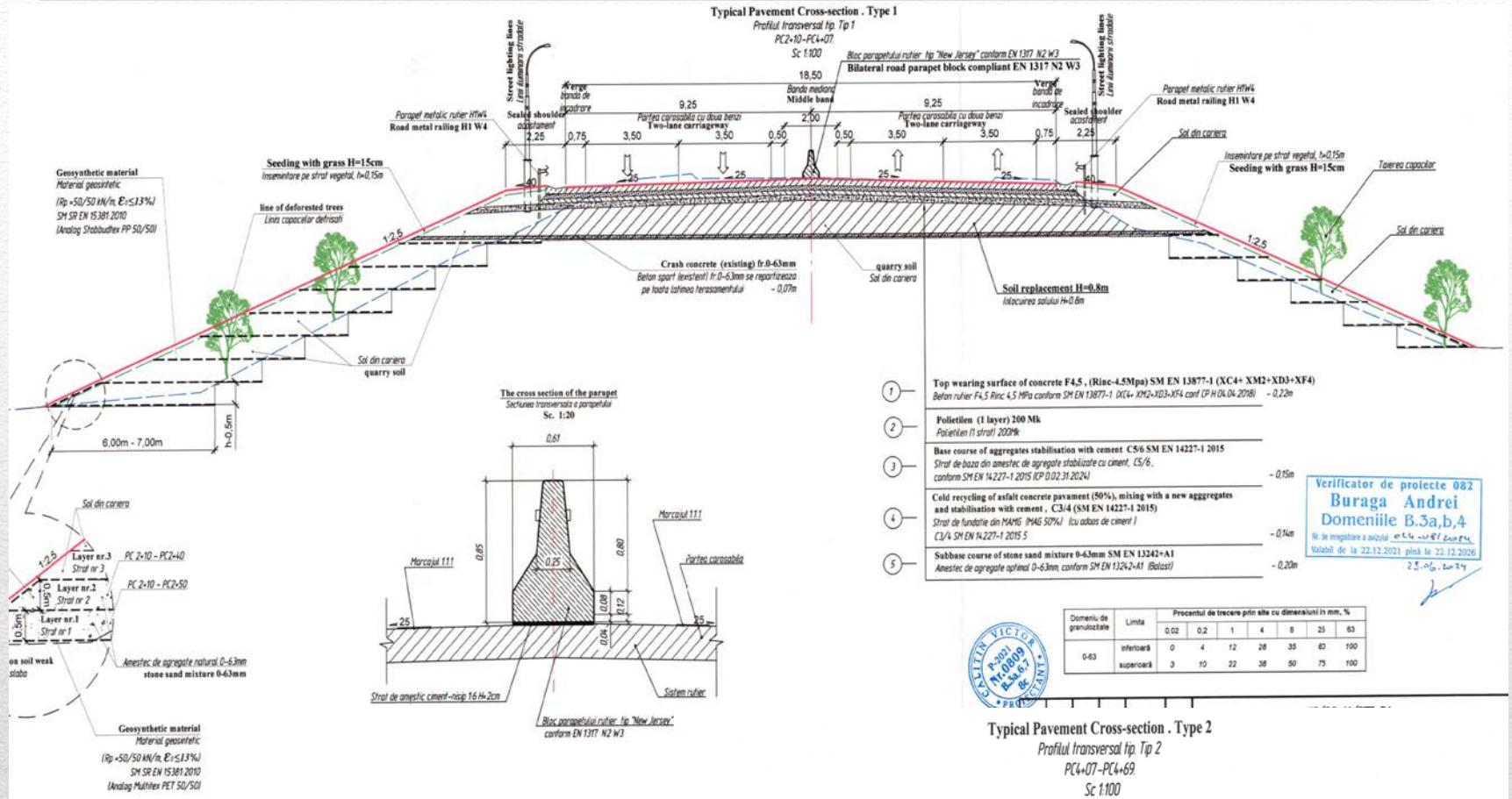

- Wearing course of concrete F4,5 (XC4+XM2+XD3+XF4) – 22 cm;
- Poliethilen (1 layer) 200 Mk;
- Base course of aggregates stabilization with cement C5/6;
- Cold recycling of asphalt concrete pavement (50%), mixing with new aggregates and stabilization with cement, C3/4;
- Subbase course of stone sand mixture 0-63 mm

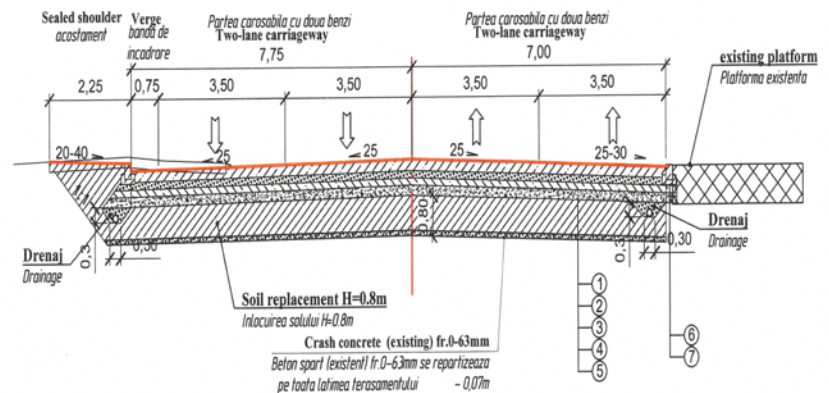

The scheme of the execution of road wear deformation joints.
Schema executării rasturilor de deformare a ambrăcămintei rutiere
 Sc.1:100

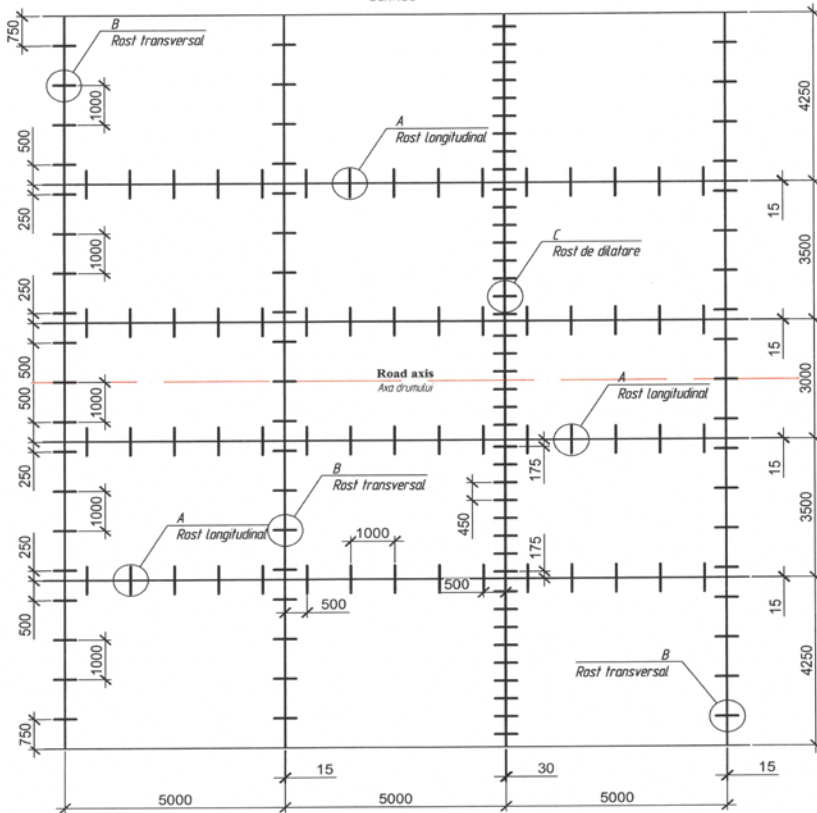

Construcția rostului transversal de comprimare - B
Construction of the transverse compression joint - B
 Sc.1:10

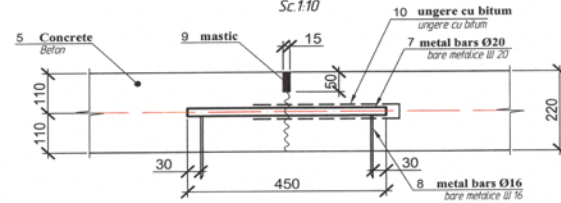

Construcția rostului transversal de dilatare - C
Construction of the transverse expansion joint - C
 Sc.1:10

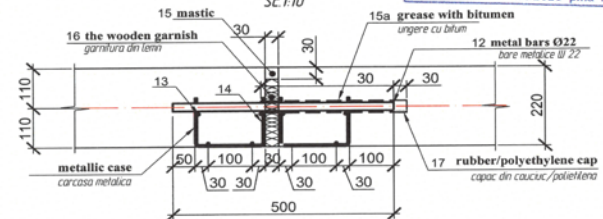

Verificator de proiecte 082
 Buraga Andrei
 Domeniile B.3a,b,4
 Valabil de la 22.12.2021 până la 22.12.2026

1. Rostul de comprimare "B" se prevăd cu pasul de 5,0 m, cu lățimea de 15 mm.
2. Rostul de dilatare "C" se amenajează peste 50 m (peste 10 dale), cu lățimea de 30 mm.
3. Toate dimensiunile sunt date în milimetri.
4. Desenul este elaborat conform proiectului tip nr.3.503-71 „Îmbrăcămintă rutiere a drumurilor auto de uz general, Recomandări metodice la proiectarea îmbrăcămintei rigide”.
5. Tehnologia de executarea a îmbrăcămintei rutiere din beton monolit conform ВСН139-80 Инструкция по строительству ц/б покрытий автомобильных дорог.

1. The compression joint "B" is provided with a step of 5.0 m, with a width of 15 mm.
2. The expansion joint "C" is arranged over 50 m (over 10 slabs), with a width of 30 mm.
3. All dimensions are given in millimeters.
4. The drawing is developed according to project type no. 3.503-71 "Road clothing for general purpose roads, Methodical recommendations for the design of rigid clothing".
5. Technology of execution of monolithic concrete road dressing according to BCH139-80 „Instructions for the construction of cement-concrete road surfaces”.

The construction of the longitudinal joint - A
Construcția rostului longitudinal - A
 Sc.1:10

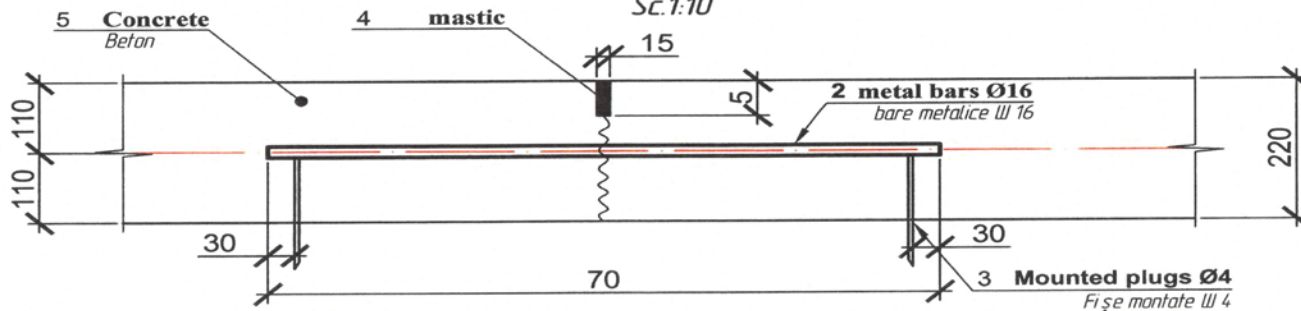



THANK YOU!